

K01 Level Switch



Operating Instructions

Teklab Sas
Via Santhià, 94 – 41100 Modena, Italy
Tel. 0039 059 375498 Fax 0039 059 376294
info@teklab.eu www.teklab.eu

Summary

1. Note	2
2. Instrument Inspection	2
3. Specific Application	3
4. Operating Principle	3
5. Technical Data of the Instrument	4
6. Electrical Connection	4
7. Installation instruction	5
8. Mechanical Dimensions	6
9. Recommendation	6

1. Note

Please read and take note of these operating instructions before unpacking and commissioning. The instruments may only be used, maintained and installed by personnel familiar with the operating instructions and the applicable health and safety requirements.

2. Instrument Inspection

The instruments are inspected before dispatch and sent out in perfect condition. Should damage to the instrument be visible, we recommend close inspection of the delivery package. In cases of damage, please immediately inform the forwarder as he is liable for any damage in transit.

Scope of Supply

* Level Switch K01 and o-ring with nut when requested.

3. Specific Application

The optical level switch has been designed for use in level monitoring applications for the control of the liquid presence/absence and can be suitable for a lot of applications. The switch has no moving parts, thus it is particularly suited for monitoring media where high reliability is needed.

For minimum / maximum level detection the switch must be mounted at the desired height and gives an alarm when low (or high) liquid level is detected.

4. Operating Principle

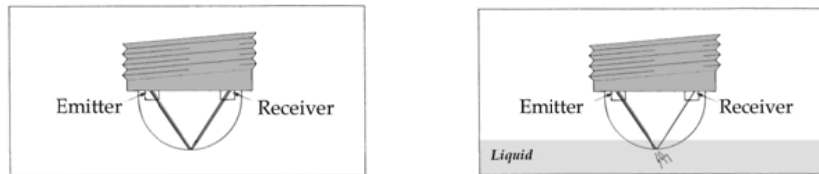

The sensors contain an infrared-ray emitter and an optical receiver. In air (liquid not present), all the light emitted is reflected - internally - by the dome and then redirected to the receiver. When the liquid reaches the sensor dome, a big amount of the light emitted is lost in the liquid and the sensor senses its presence.

5. Technical Data of the Instrument

OPERATION MODE	Detect liquid presence with contact
REPEATABILITY	± 2 mm
BODY MATERIALS	Polysulphone (PSU) charged with glass
SENSIBLE DOME	Polysulphone (PSU) charged with glass
ELECTRONIC PROTECTIONS	Transient over voltage, reverse polarity, output short-circuit (depending on models)
MAX. TEMPERATURE RANGE	From -0°C up to +60°C
STORAGE TEMPERATURE	From -40°C up to +85°C
SUPPLY VOLTAGE	10 – 28 VDC or 24 VAC ± 10% 50 or 60 Hz
OUTPUT TYPE	AC output or NPN, NPN open collector, PNP for DC model
AC / DC OUTPUT CURRENT	up to 100 mA Max (depending on temperature range)
OUTPUT MODE	Output Normally Open or Closed in air
DELAY TIMES	Customizables depending on application needs
MAX PRESSURE	up to 10 bar
TORQUE TIGHTEN	5 Ntm

6. Electrical Connection

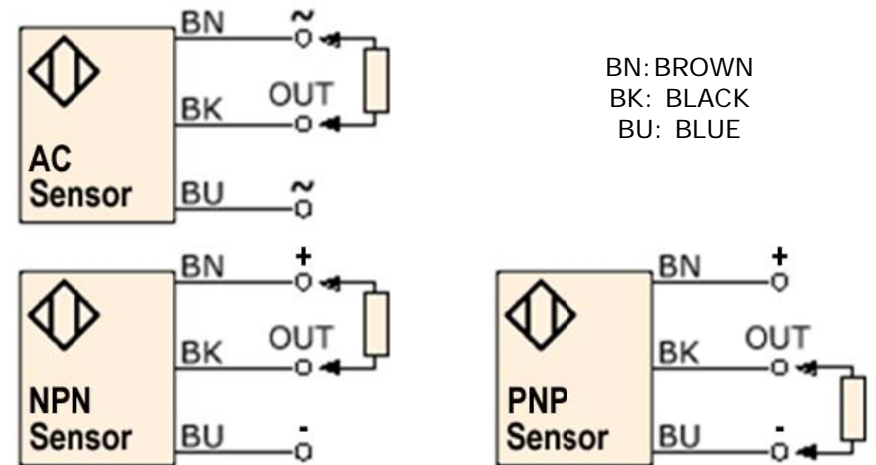

7. Installation instruction

- Only qualified personnel should carry out installation
- Protect hands and face from contacting the liquids, which may contain harmful acid.
- Depressurise the system before attempting any work
- Switch off power supply and isolate system
- If fitting to an existing installation, drain the liquid of the system if present
- Assemble the switch on the system

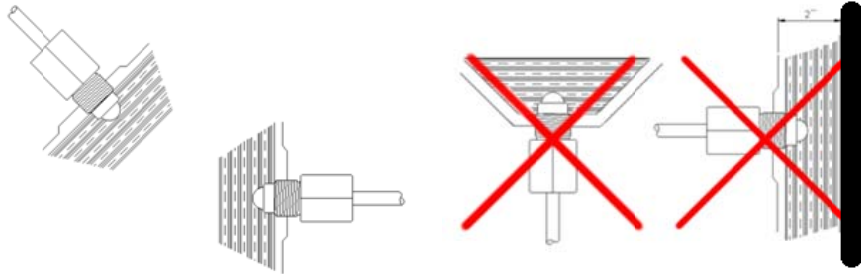

- Do not install sensor close to infrared sources.
- Dome of the sensor must be at least 2" (~ 50mm) from any reflective surfaces. Please contact Teklab for lower distances.
- Do not install the sensor in a stagnation point of the liquid
- Do not use to detect freezing liquids
- The mounting position corresponds to the desired switching point.
- The optical sensor tip must be free of insulating materials.
- The sensor tip must be installed in a way that it is not in contact with any moving parts inside the tank or the reservoir.
- During installation the sensor tip may not be touched with any device which could scratch or damage the dome in any way.
- It is recommended that for conical threads proper tapes should be applied to the threads itself on the switch body. The switch should then be threaded and sealed by using a correct wrench and under no circumstances by using any other device which may damage the housing (please verify torque tighten).

8. Mechanical Dimensions

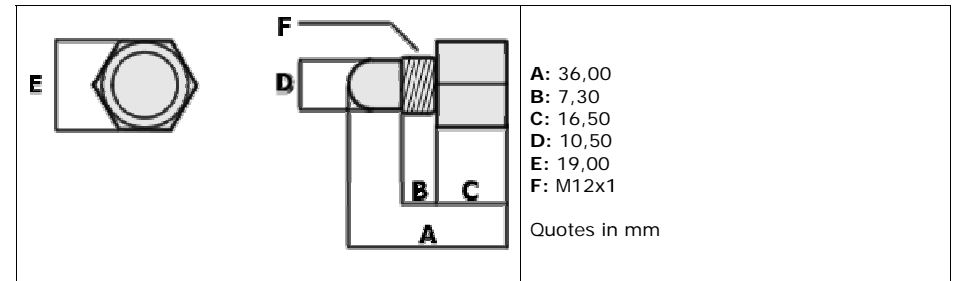

9. Recommendation

While the device is totally maintenance free we recommend that the sensor dome be cleaned periodically during major servicing.

Teklab is not to be held responsible for erroneous literature regarding dimensions, applications, etc. stated in this document. Products, specifications and data in this literature are subject to change without giving any evidence. The information given herein is based on technical data and tests which Teklab acquired during years of experience and believe to be reliable and which are in compliance with technical knowledge of today. It is intended only for use by persons having the appropriate technical knowledge and skills, at their own discretion and risk. Since conditions of use are outside of Teklab control we can not assume any liability for results obtained or damages occurred due to improper application.